

# Outline

## Part I (Monday)

- Introduction
- Snow analysis
- Screen level parameters analysis

## Part II (Tuesday)

- **Soil moisture analysis**
  - **OI and EKF analyses**
  - Use of satellite data: ASCAT and SMOS
- Summary and future plans



# Interaction between Soil Moisture (SM) and Atmosphere

**The hydrological 'Rosette'** (P. Viterbo, PhD thesis, «The representation of surface processes in General Circulation Models » ECMWF, 1996)

A → B: After rain, Evaporation at potential rate, Atmospheric control.

B → C: Below field capacity soil moisture, Limitation of root extraction, Soil control.

C → D: Precipitation & relatively dry soils, High infiltration rate  $I_r$ , Atmospheric control.

D → A: Precipitation and soil near saturation, Soil infiltration is reduced. Excess goes in runoff, Soil control.

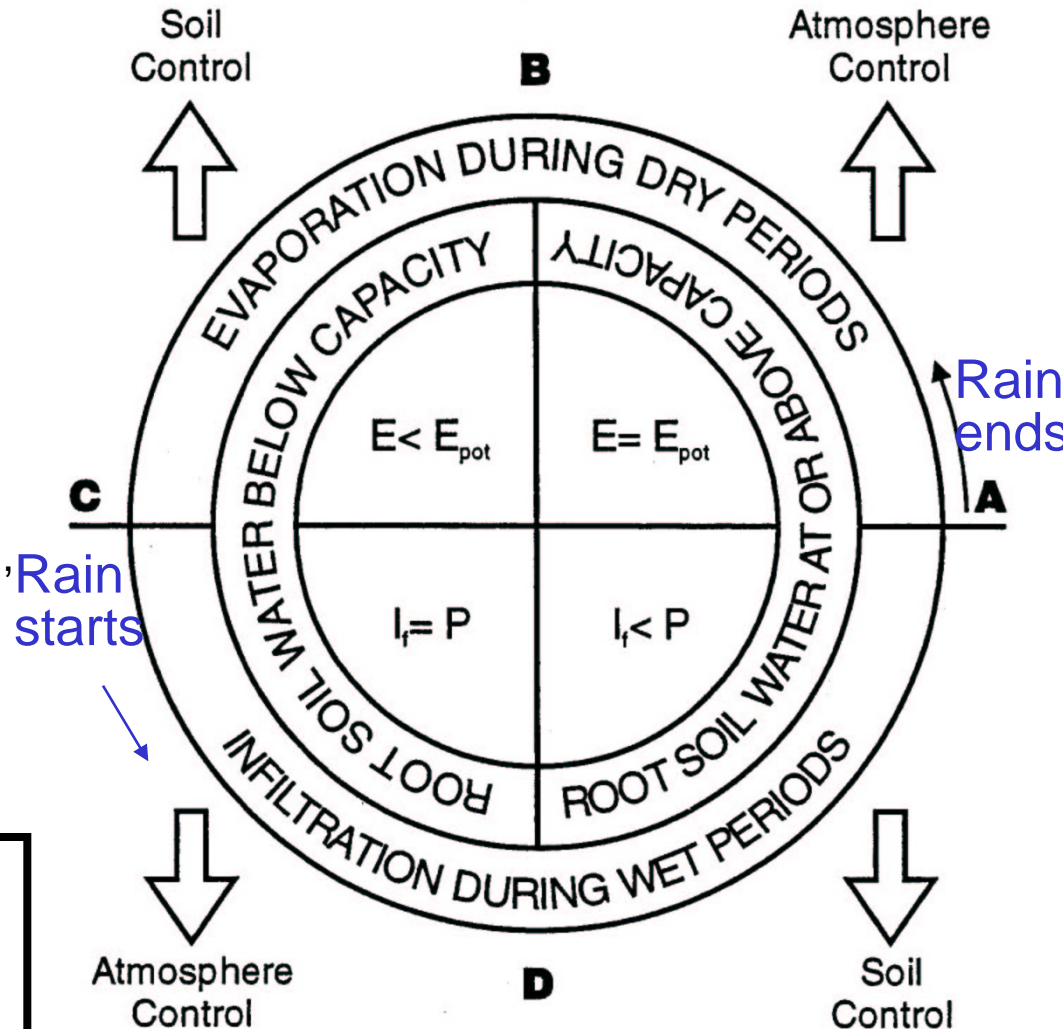

Simple representation, but illustrates how soil-plant-atmosphere interactions are controlled by different processes depending on the conditions.

# Interaction between Soil Moisture (SM) and Atmosphere

Based on a multi-model approach: characterization of the strength of the coupling between surface and atmosphere.

(Koster et al, Science 2004).

SM, variable of interface

Partition LE/H

Vegetation phenology,

Soil respiration,

Biogeochemical cycle

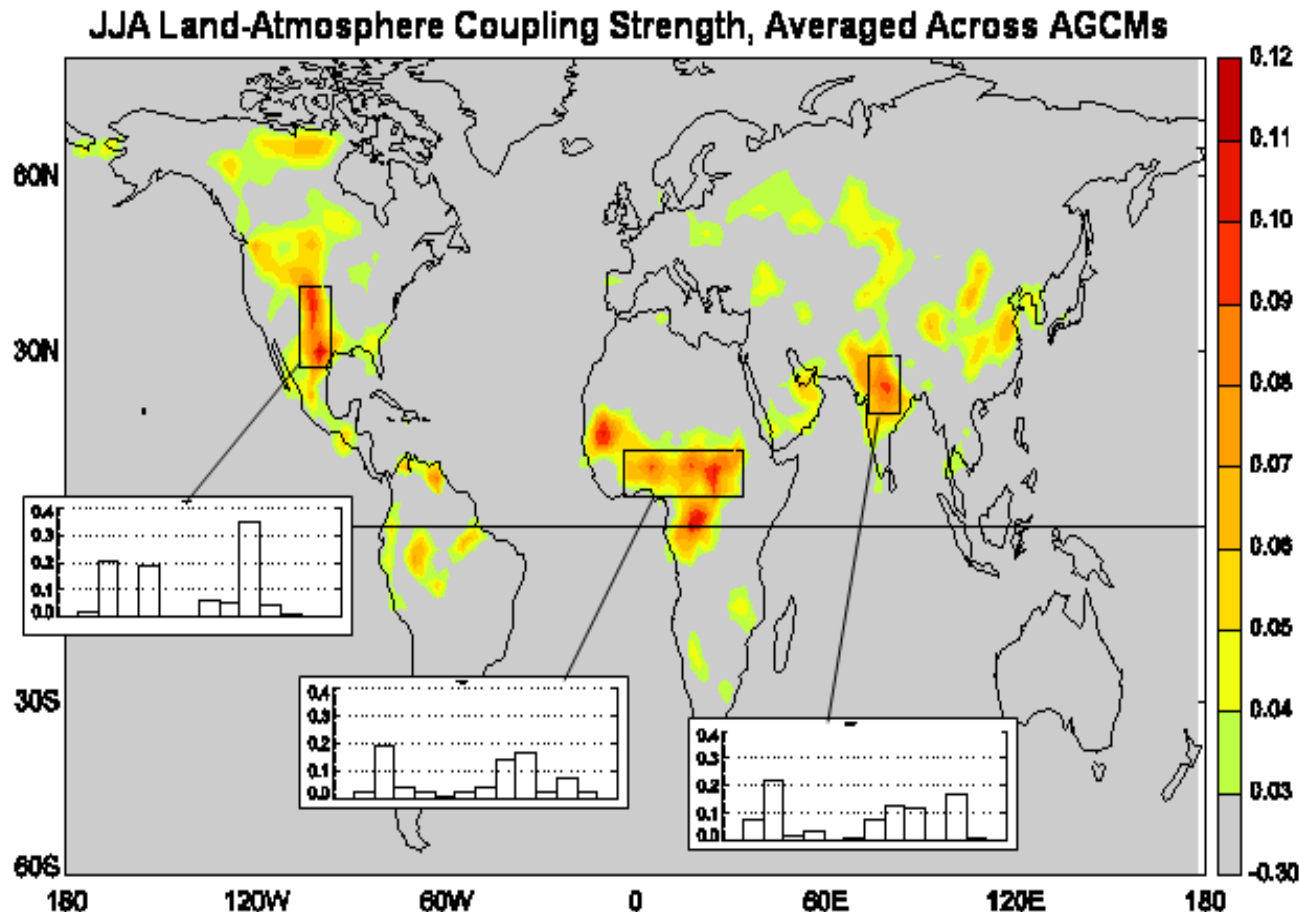

Hot spot areas → strong feedback of soil moisture on precipitation

# A short history of soil moisture analysis at ECMWF

## ➤ Nudging scheme (1995-1999) soil moisture increments $\Delta\Theta$ ( $\text{m}^3\text{m}^{-3}$ ):

$$\Delta\Theta = \Delta t D C_v (q^a - q^b)$$

D: nudging coefficient (constant=1.5g/Kg),  $\Delta t = 6\text{h}$ , q specific humidity

Uses upper air analysis of specific humidity

Prevents soil moisture drift in summer

## ➤ Optimal interpolation 1D OI (1999-2010)

(Mahfouf, ECMWF News letter 2000,  
Douville et al., Mon Wea. Rev. 2000)

$$\Delta\Theta = A (T^a - T^b) + B (Rh^a - Rh^b)$$

A and B: optimal coefficients

OI soil moisture analysis based on a dedicated screen level parameters (T2m Rh2m) analysis

## ➤ Simplified Extended Kalman Filter (EKF), Nov 2010-

- Motivated by better using T2m, RH2m
- Opening the possibility to assimilate satellite data related to surface soil moisture.

Drusch et al., GRL, 2009  
de Rosnay et al., QJRMS 2013

# 1D Optimal Interpolation (OI) analysis

**1D-OI for SM : used in operations from 1999 to 2010, and currently in ERA-Interim, Météo-France, CMC, ALADIN, HIRLAM**

**Relies on the link between soil variables and the lowest atmospheric level:**

- Too dry soil soil → 2m air too dry & too warm
- Too wet soil soil → 2m air too moist & too cold

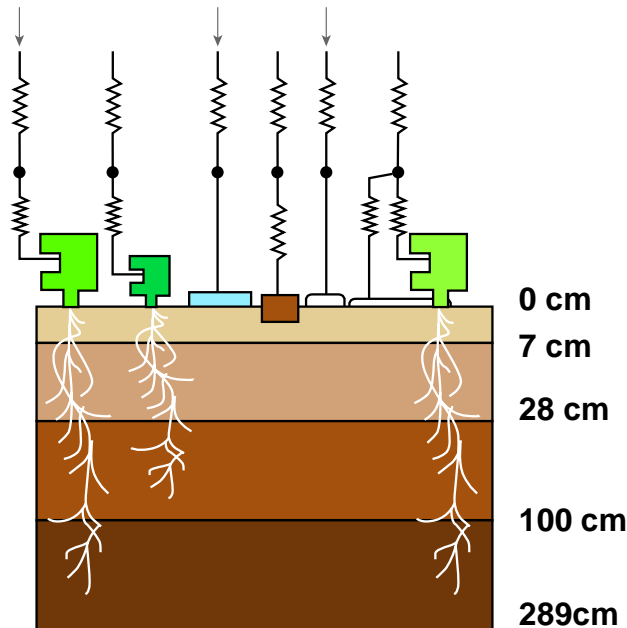

References H-TESSEL:  
Balsamo et al., JHM 2009

## H-TESSEL Land Surface Model

→ Soil Moisture increments based on the T2m and RH2m analysis increments:

$$\Delta\Theta_i = \alpha_i (T^a - T^b) + \beta_i (rH^a - rH^b)$$

For snow temperature and soil temperature (ERA-Interim and operations):

$$\Delta T = c (T^a - T^b)$$

a and b: analysis and background ; i: soil layer.  
Optimal Coefficients  $\alpha$ ,  $\beta$  and c

Quality Control: no OI when Rain, snow, freezing, wind

References OI: Mahfouf, JAM, 1991,  
Mahfouf et al, ECMWF NL 88, 2000

# Simplified EKF soil moisture analysis

For each grid point, analysed soil moisture state vector  $\theta_a$ :

$$\theta_a = \theta_b + \mathbf{K} (y - \mathcal{H}[\theta_b])$$

$\theta$  background soil moisture state vector,

$\mathcal{H}$  non linear observation operator

$y$  observation vector

$\mathbf{K}$  Kalman gain matrix, fn of  $\mathbf{H}$  (linearisation of  $\mathcal{H}$ ),  $\mathbf{B}$  and  $\mathbf{R}$  (covariance matrices of background and observation errors).

## Observations used:

- **Operational NWP:** Conventional SYNOP observations (T2m, RH2m)
- **Operational ASCAT DA for EUMETSAT: SM-DAS-2**
- **Research: SMOS Data Assimilation**

Drusch et al., GRL, 2009  
de Rosnay et al., ECMWF News Letter 127, 2011  
de Rosnay et al., QJRMS in press, 2013

Simplified EKF corrects the trajectory of the Land Surface Model

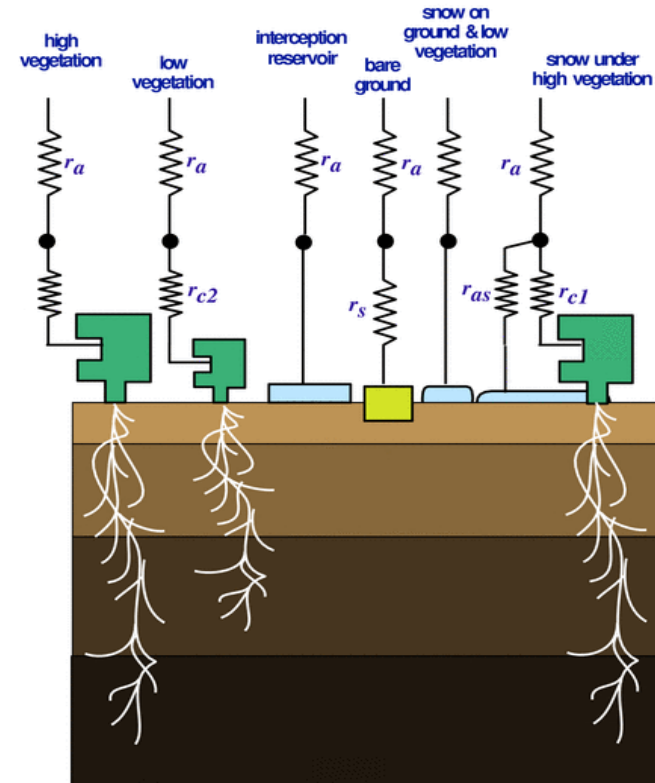

# Simplified EKF surface analysis

The analysis is obtained by an optimal combination of the observations and the background (short-range forecast):

$$\theta_{\mathbf{a}}(t) = \theta_{\mathbf{b}}(t) + \mathbf{K} (\mathbf{y}(t) - \mathcal{H}[\theta_{\mathbf{b}}(t)])$$

where  $\mathbf{K}$  is the gain matrix:

$$\mathbf{K} = (\mathbf{B}^{-1} + \mathbf{H}^T \mathbf{R}^{-1} \mathbf{H})^{-1} \mathbf{H}^T \mathbf{R}^{-1}$$

The observation operator  $\mathbf{H}$  is the Jacobian matrix of:

$$H_{ij} = \frac{\delta y_i}{\delta \theta_j} \simeq \frac{y_i(x + \delta \theta_j) - y_i(x)}{\delta \theta_j}$$

In finite differences, the elements of the Jacobian matrix are estimated by perturbing individually each component  $\theta_j$  of the control vector  $\boldsymbol{\theta}$  by a small amount  $\delta \theta_j$ . A sensitivity analysis has been conducted to find the optimum perturbation  $\delta \theta_j$ .

# Simplified EKF computing cost

Computing Time (CPU in s) per 12h cycle:

	<b>T159 (125km)</b>	<b>T255 (80km)</b>	<b>T799 (25km)</b>	<b>T1279 (16km)</b>
<b>1D OI</b>	<b>3</b>	<b>10</b>	<b>20</b>	<b>30</b>
<b>EKF</b>	<b><math>3 \cdot 10^3</math></b>	<b><math>10^4</math></b>	<b><math>2 \cdot 10^5</math></b>	<b><math>5 \cdot 10^5</math></b>
<b>4D-Var</b>		<b><math>4 \cdot 10^5</math></b>	<b><math>10^6</math></b>	<b><math>2.5 \cdot 10^6</math></b>

**EKF running on several processors → Elapsed time ~ 500s at the operational high resolution (T1279)**



# Simplified EKF and OI Comparison

0-1m Soil Moisture increments (mm)  
**January 2009**

OI

Soil moisture analysis more active in the summer hemisphere than in the winter hemisphere

EKF

$|EKF| - |OI|$

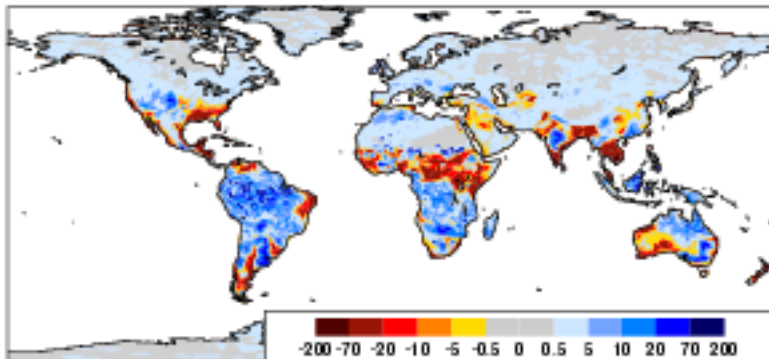
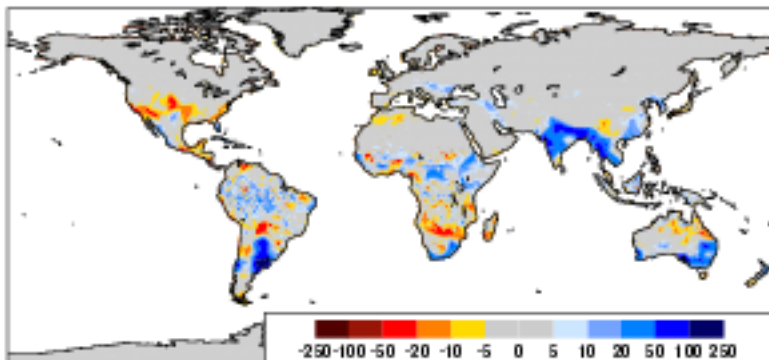
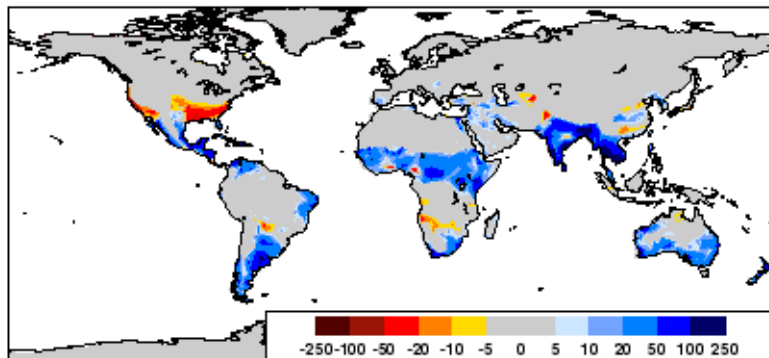

# Simplified EKF and OI comparison

0-1m Soil Moisture increments (mm)  
**July 2009**

OI

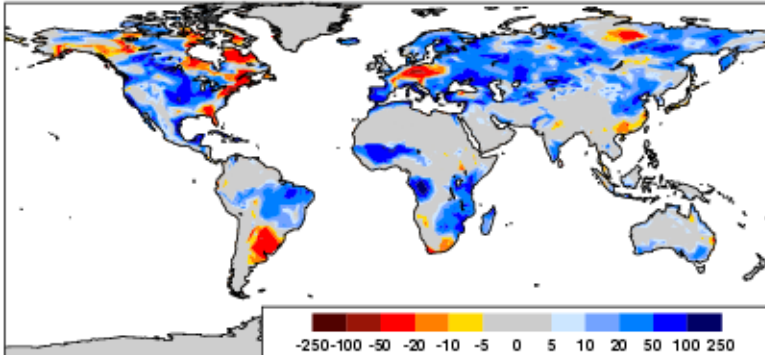

EKF

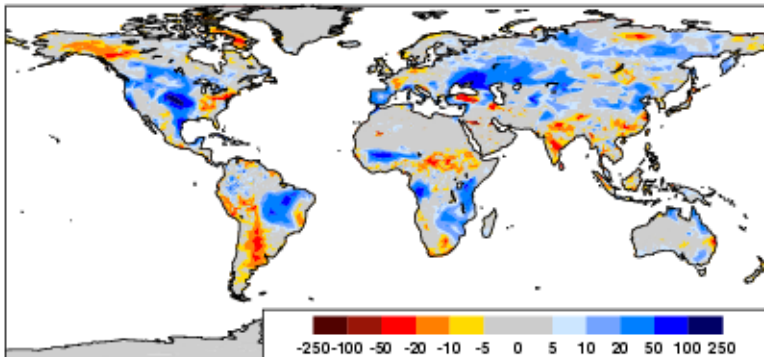

Much reduced root zone increments  
with the EKF compared to the OI

$|EKF| - |OI|$

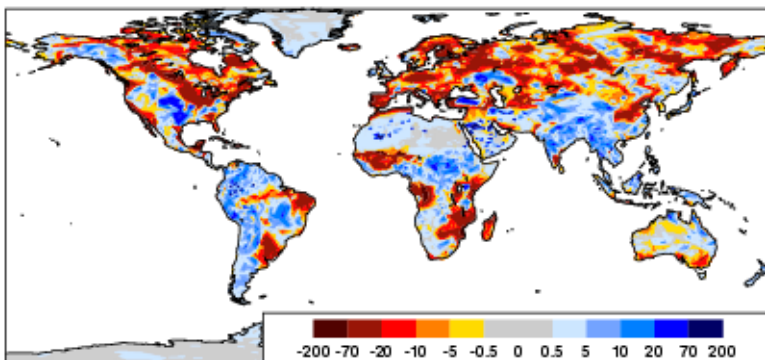

# Simplified EKF and OI comparison

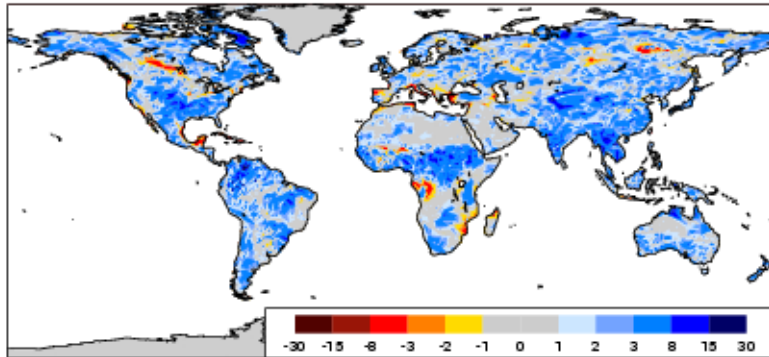

Layer 1 (0-7cm)

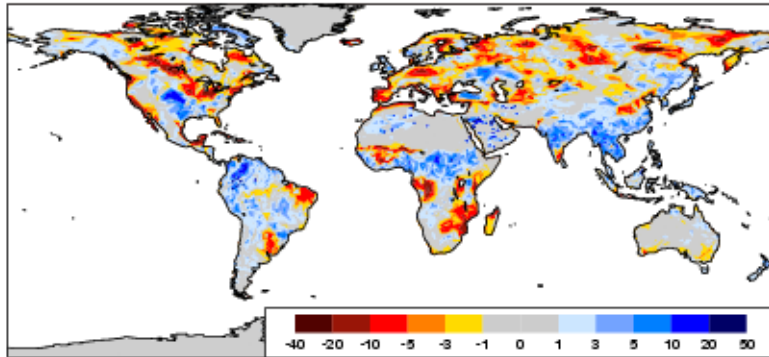

Layer 2 (7-28cm)

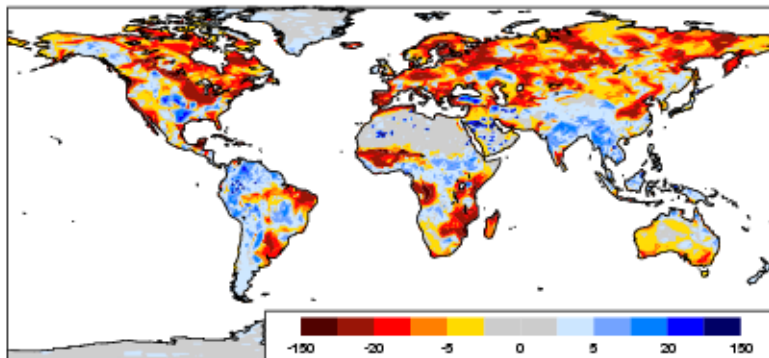

Layer 3 (100-289 cm)

## Vertical Profile of Soil Moisture increments difference $|EKF| - |OI|$ July 2009

- EKF compared to OI:
- . Reduce increments at depth
  - . Increase increments for top soil layer
  - . Overall reduced increment

# Simplified EKF and OI comparison

0-1m Soil Moisture increments for July 2009 (mm)

$|EKF| - |OI|$

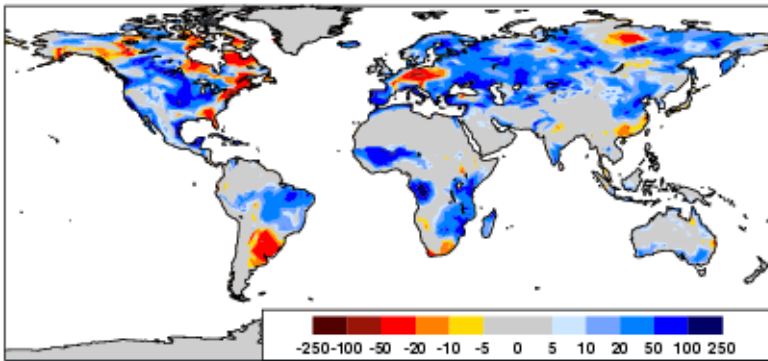

OI

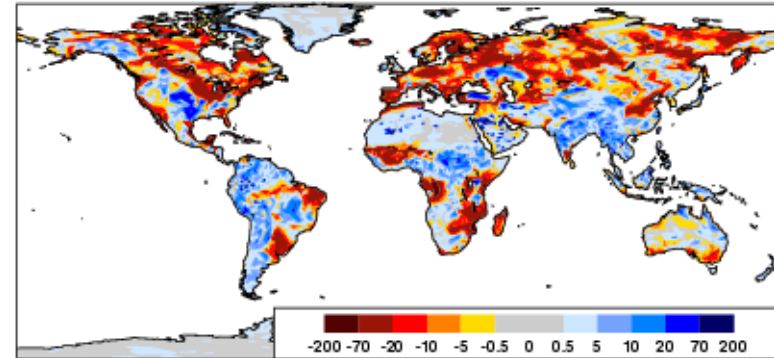

Global Soil Moisture Increments (1st meter of soil)

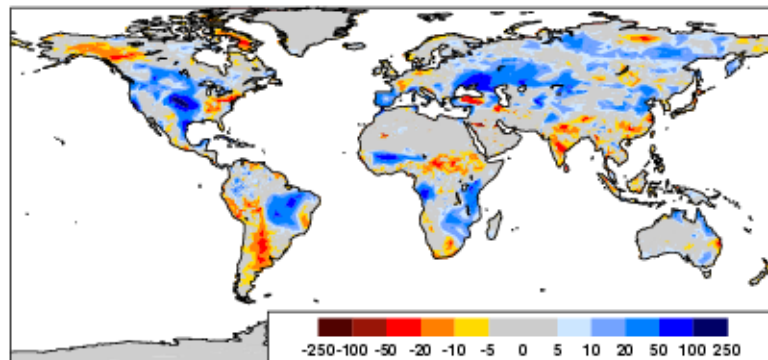

EKF

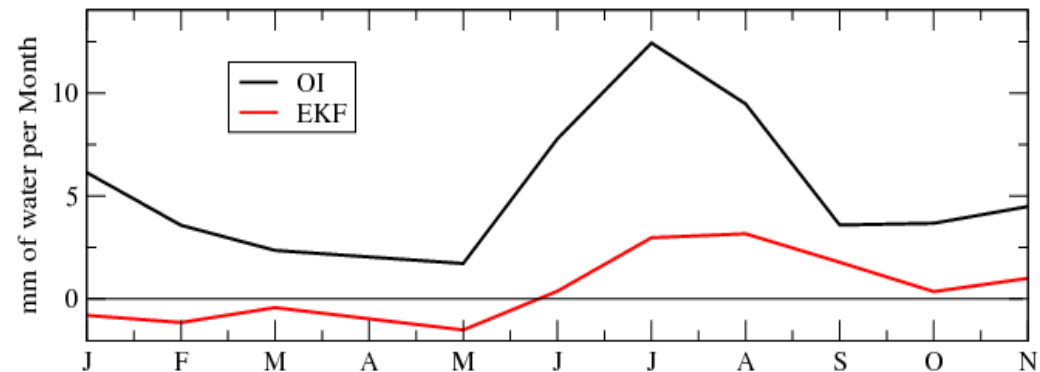

- Two 1-year analysis experiments using the OI and the EKF
- Reduced increment with the EKF compared to the OI
- EKF accounts for non-linear control on the soil moisture increments: meteorological and soil moisture conditions
- **EKF prevents undesirable and excessive soil moisture corrections**

# Soil Moisture Analysis verification

Validated for several sites across Europe (Italy, France, Spain, Belgium)

## Verification of ECMWF SM over the SMOSMANIA Network

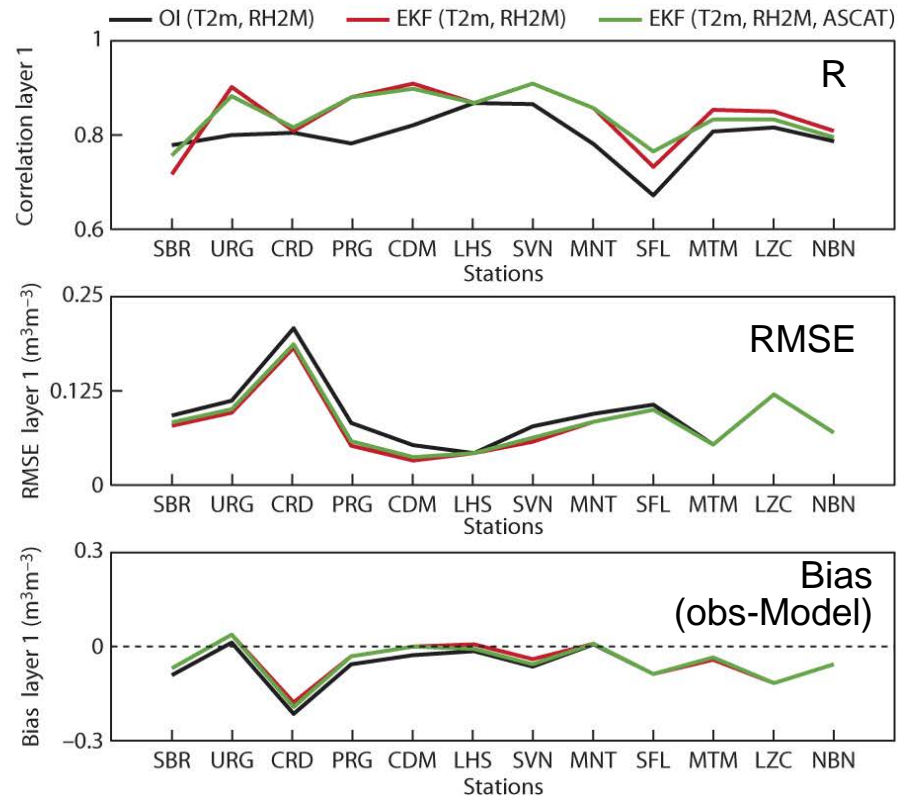
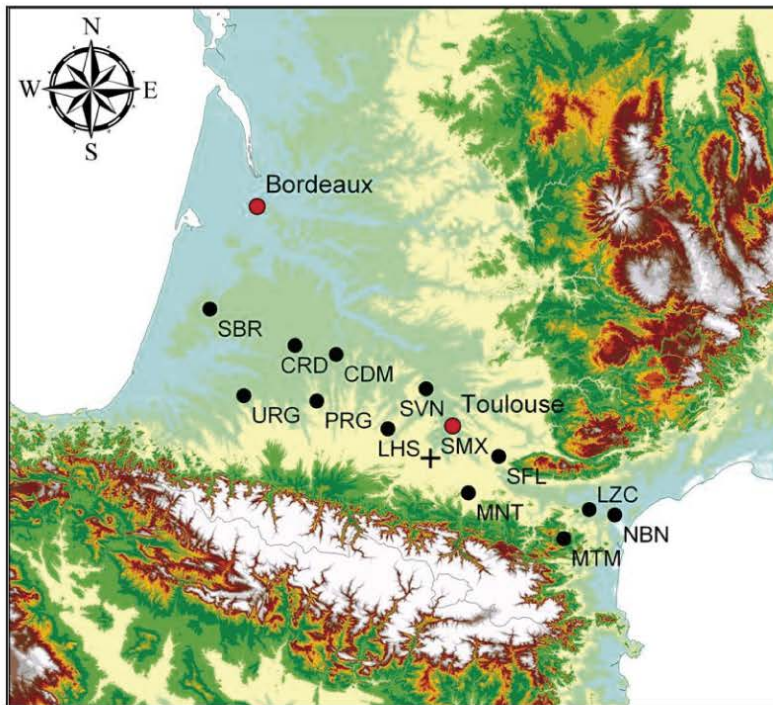

Compared to the OI, the EKF improves soil moisture

# T2m 48-h Forecast Evaluation

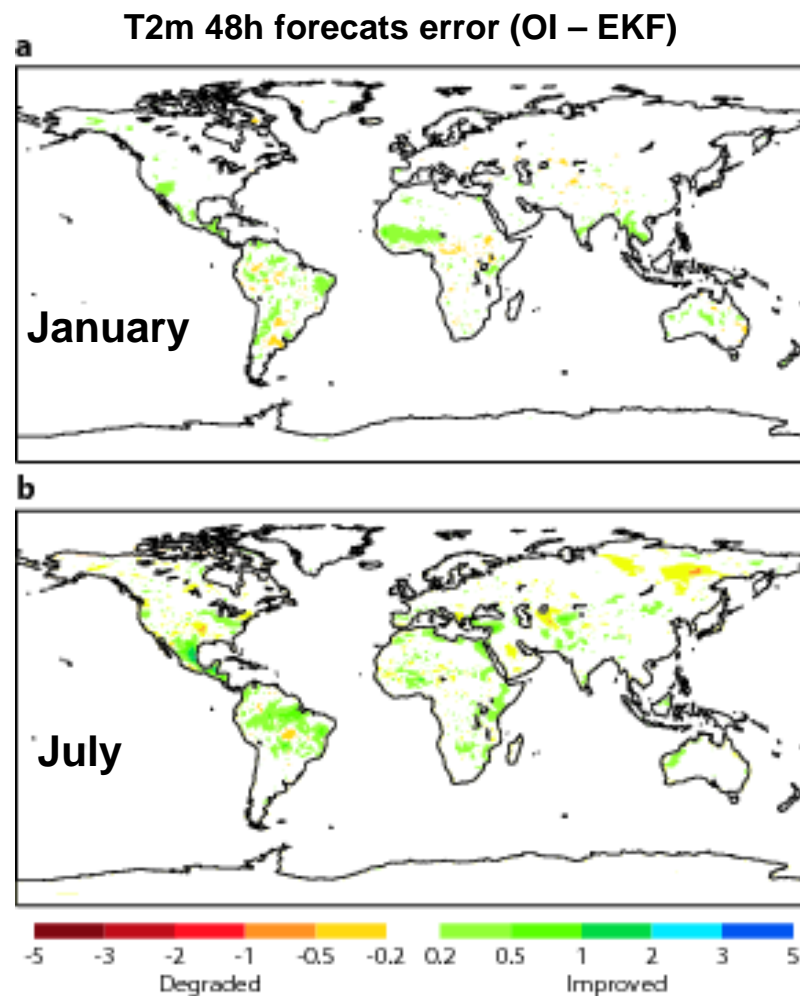
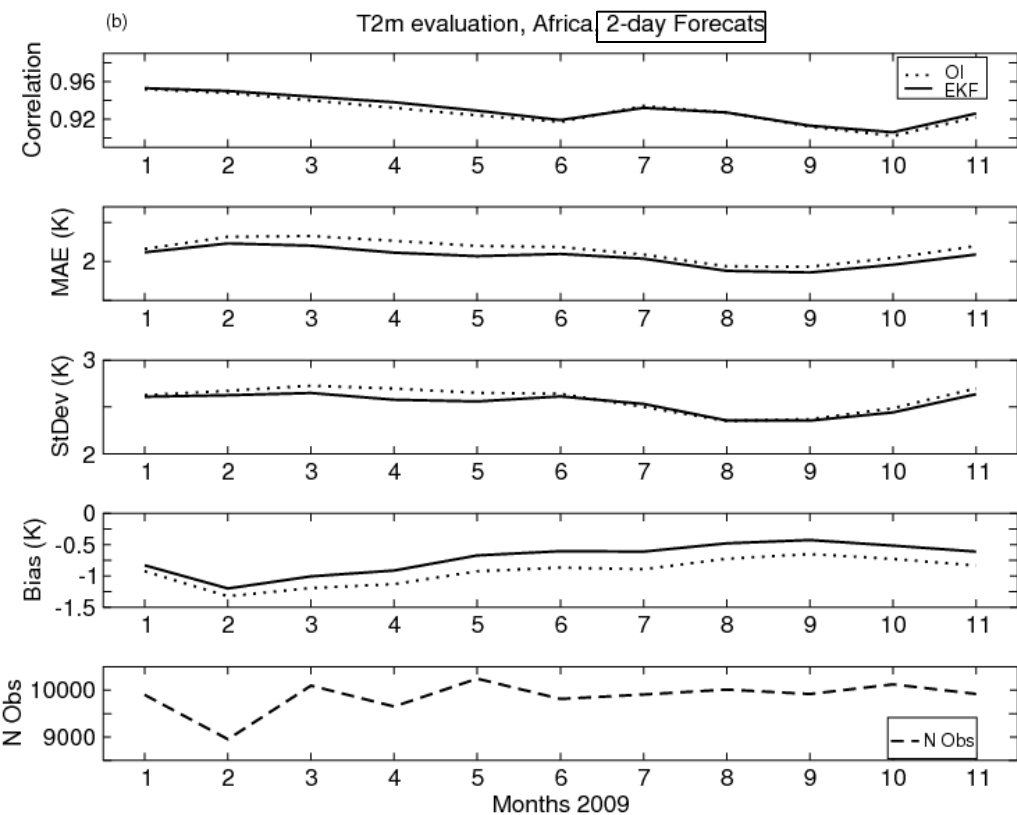

- EKF improves (compared to the 1D OI) analysis and FC of Soil Moisture and Screen level parameters
- EKF enables the use of satellite data for the surface

# EKF surface analysis

- Dynamical estimates of the Jacobian Matrix that quantify accurately the physical relationship between observations and soil moisture
  - Improves (compared to 1D OI) both soil moisture and screen level parameters (T2m, RH2m)
- Flexible to account for the land surface model evolution
- Possible to use of new generation of satellite data:
  - SM active microwave (MetOp/ASCAT, L-band SMAP)
  - SM passive microwave (L-band SMOS, SMAP)
- Makes it possible to combine different sources of information

**SYNOP**



**ASCAT**



**SMOS**



# Outline

## Part I (Monday)

- Introduction
- Snow analysis
- Screen level parameters analysis

## Part II (Tuesday)

- **Soil moisture analysis**
  - OI and EKF analyses
  - **Use of Satellite data ASCAT and SMOS**
- Summary and future plans





# Satellite data for NWP soil moisture analysis

**Active microwave data:**  
**ASCAT:** Advanced Scatterometer  
 On MetOP-A (2006-), MetOP-B (2012-)  
 C-band (5.6GHz)  
**NRT Surface soil moisture**  
 Operational product  
 → ensured operational continuity

**Passive microwave data:**  
**SMOS:** Soil Moisture & Ocean Salinity  
 L-band (1.4 GHz)  
**NRT Brightness Temperature**  
 Dedicated soil moisture mission  
 → Strongest sensitivity to soil moisture

STATISTICS FOR SOIL MOISTURE FROM METOP-B/ASCAT

STATISTICS FOR RADIANCES FROM FROM SMOS

## Operational Monitoring of surface soil moisture related satellite data: ASCAT soil moisture ( $m^3m^{-3}$ )      SMOS Brightness temperature (K)

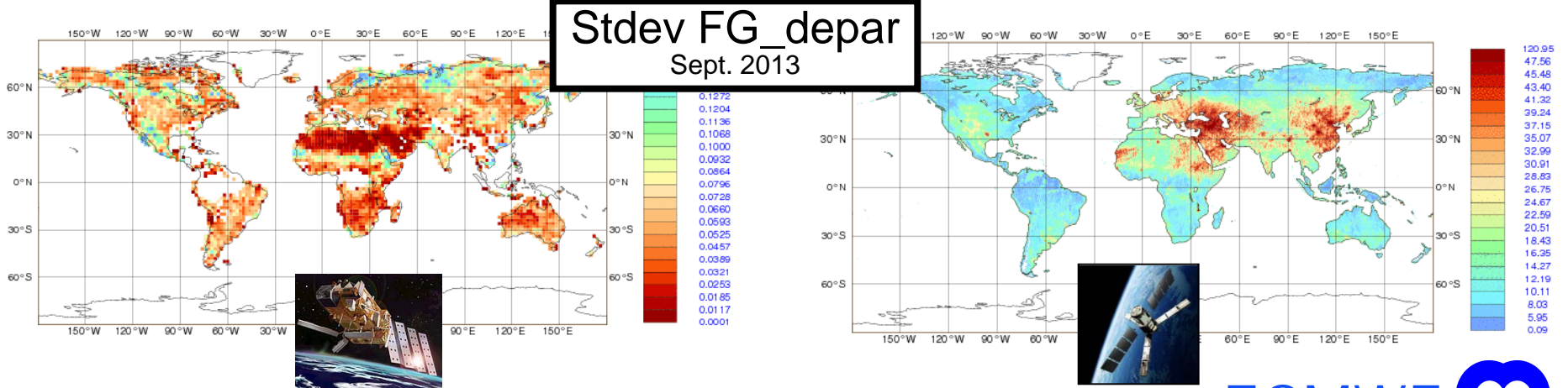

# ASCAT Bias Correction

- ASCAT is a soil moisture index (0-1) ; ECMWF uses volumetric SM
- Systematic differences between model and observations
- Data assimilation aims at correcting for the model random errors, so a bias correction method is necessary to match the observations 'climatology' to that of the model (→ See course of Hans Hersbach on Bias Correction)

→ **For soil moisture, we follow the simplified Bias correction**

proposed by Scipal et al., WRR 2008, based on Cumulative Distribution Function Matching: **CDF-Matching**

Revised in 2011 to account for seasonal cycle (de Rosnay et al., Res. Memo. 2011)

# ASCAT Bias Correction (CDF matching)

- ASCAT soil moisture index  $ms_{ASCAT}$
- Model soil moisture  $\theta$  ( $m^3/m^3$ )

→ Simple Cumulative Distribution Function (CDF) matching (Scipal et al., 2008)

— —

a and b are CDF matching parameters computed **on each model grid point**

**ASCAT CDF-matching has two objectives:**

- ASCAT index converted to model equivalent volumetric soil moisture
- Bias correction

ASCAT matching parameters  
(de Rosnay et al., ECMWF Res memo  
R43.8/PdR/11100, 2011)

# ASCAT Bias correction

Efficient data assimilation relies on accurate bias correction

## ASCAT revised bias correction

de Rosnay et al., RD memo 2011

ASCAT index

ECMWF soil moisture

(ASCAT old BC)

ASCAT new BC static

ASCAT new BC dynamic

Time series at 43.825N 1.1767E (South West France)

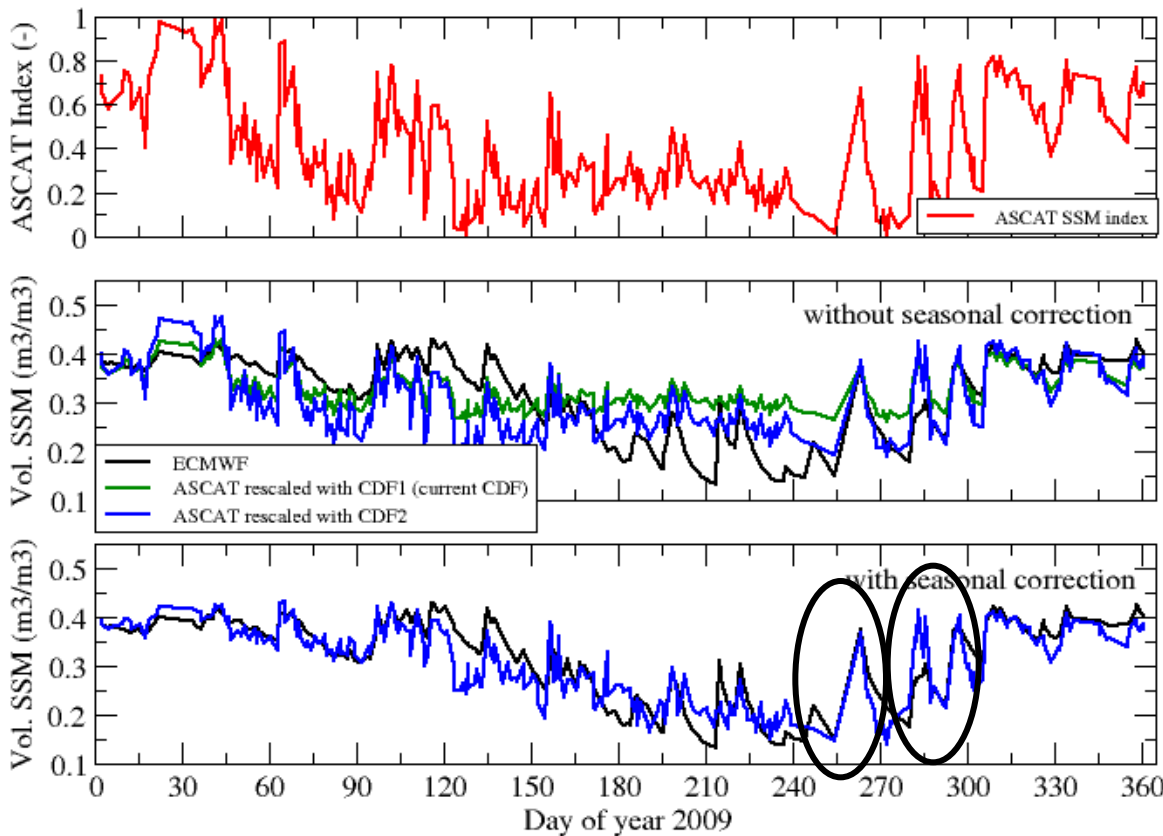

# ASCAT-A and ASCAT-B

- Metop-B launched in September 2012
- ASCAT-B soil moisture acquisition since 23 November 2012, soil moisture operational monitoring since 06 December 2012
- Consistent ASCAT-A and ASCAT-B soil moisture

ASCAT SM – Model  
(First guess departure,  $\text{m}^3.\text{m}^{-3}$ )  
23-24 Nov 2012

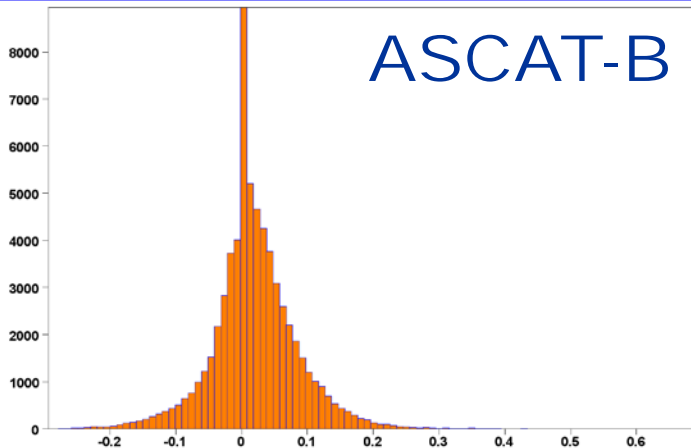
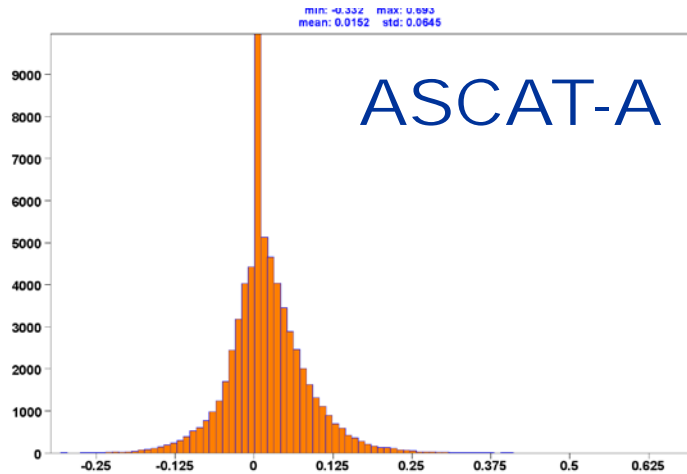

	Nb	Mean $\text{m}^3.\text{m}^{-3}$	Std $\text{m}^3.\text{m}^{-3}$
ASCAT-A	64893	0.0152	0.0645
ASCAT-B	65527	0.0149	0.0663

Operational monitoring:

<http://www.ecmwf.int/products/forecasts/d/charts/monitoring/satellite/slmoist/>

# Root Zone Soil Moisture Retrieval

**Satellite data → Surface information**

Top soil moisture sampling depth: 0-2cm ASCAT, 0-5cm SMOS

## Root Zone SM Profile

Variable of interest for  
Soil-Plant-Atm interaction,  
Climate, NWP and  
hydrological applications

Accurate retrieval  
requires to account for  
physical processes

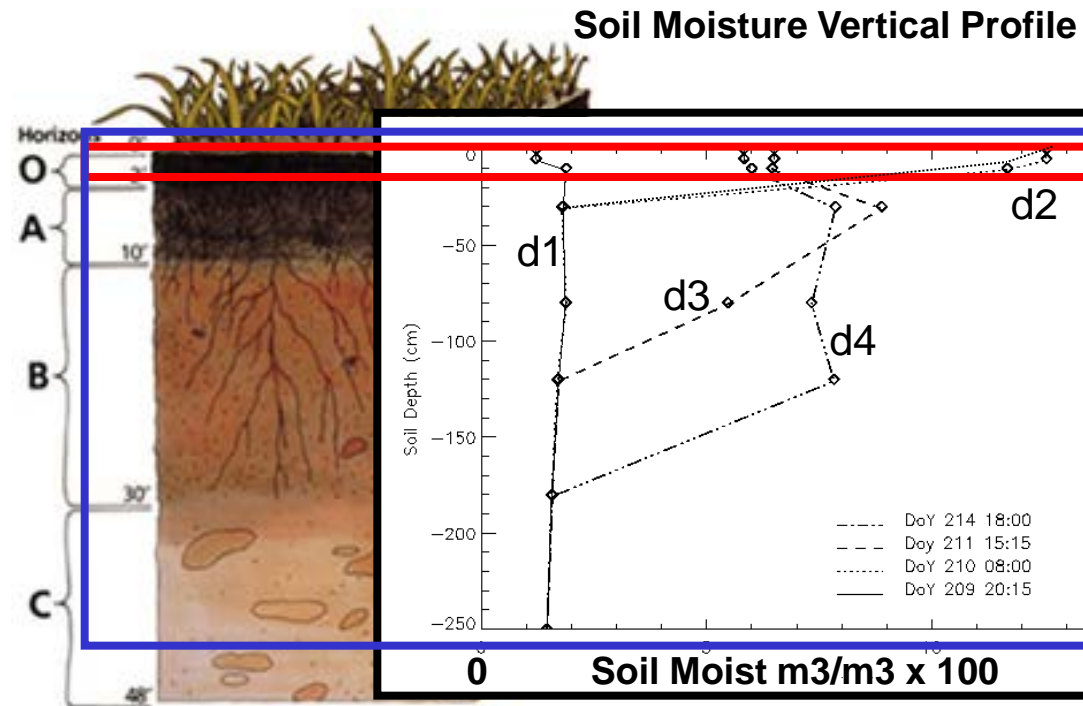

→ Space agencies retrieval of level 3 / level 4 products rely on data assimilation approaches.

# ASCAT soil moisture data assimilation

The EUMETSAT  
Network of  
Satellite Application  
Facilities



## EUMETSAT Hydrology SAF

ECMWF Atmospheric conditions



SYNOP  
T2m RH2m

EKF  
Soil Moisture  
Analysis

**SM-DAS-2:  
ASCAT Root  
Zone**

**ASCAT  
Surface SM  
Bias corrected**

(de Rosnay et al., ECMWF  
Res. Memo, 2011)

H-SAF CDOP: SM-DAS-2 Production chain

4 layers:  
0-7cm  
7-28 cm  
28-100 cm  
100-289cm

**Quality Control → use data when:**

- Topographic complexity  $\leq 20$
- Wetland Fraction  $\leq 15$
- Noise level  $\leq 8$
- processing flag=0

# ASCAT soil moisture data assimilation

ECMWF VT: Tuesday 4 September 2012 00UTC Surface:  
H14 H-SAF CDOP - Copyright © Eumetsat

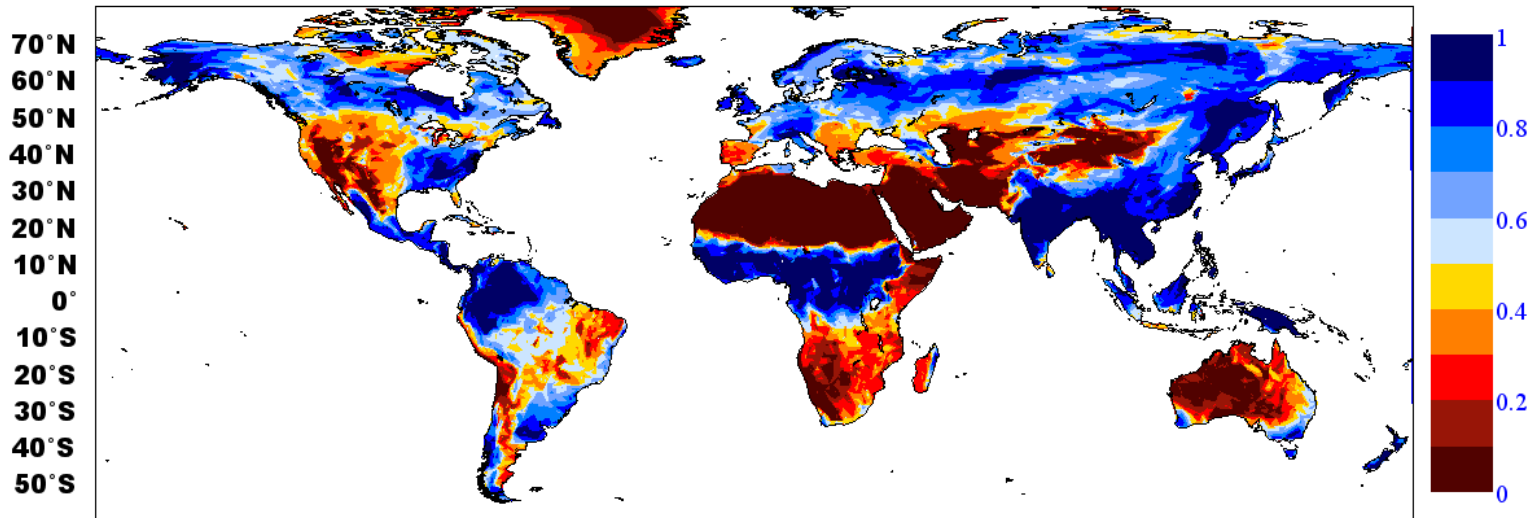

- SM-DAS-2: ASCAT Root Zone Soil Moisture Product**
- **Daily Soil Moisture product valid at 00:00 UTC**
- **Daily Global coverage**

**SM-DAS-2: Operational H-SAF since July 2012;**

[hsafcdop@meteoam.it](mailto:hsafcdop@meteoam.it)

The EUMETSAT  
Network of  
Satellite Application  
Facilities

**HSAF**  
Support to Operational  
Hydrology and Water  
Management



# ASCAT soil moisture data assimilation

## SM-DAS-2 available on 4 soil layers

ECMWF VT: Tuesday 4 September 2012 00UTC Surface:  
H14 H-SAF CDOP - Copyright © Eumetsat

### Layer 1 (0-7cm)

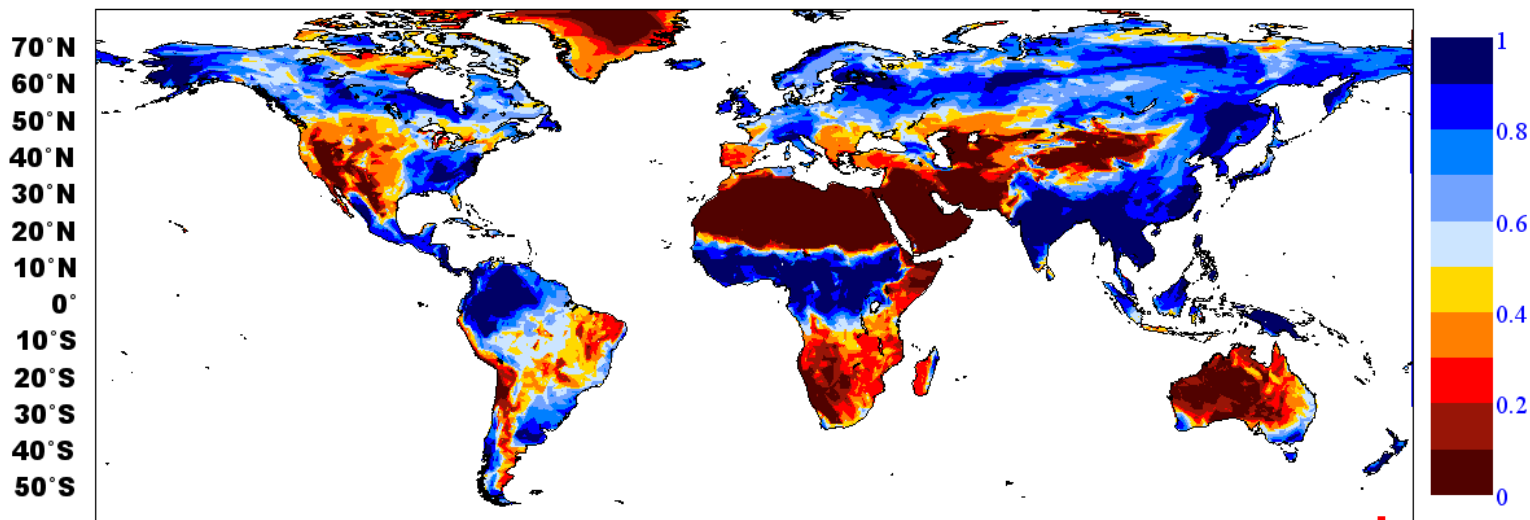

ECMWF VT: Tuesday 4 September 2012 00UTC Surface:  
H14 H-SAF CDOP - Copyright © Eumetsat

### Layer 2 (7-28cm)

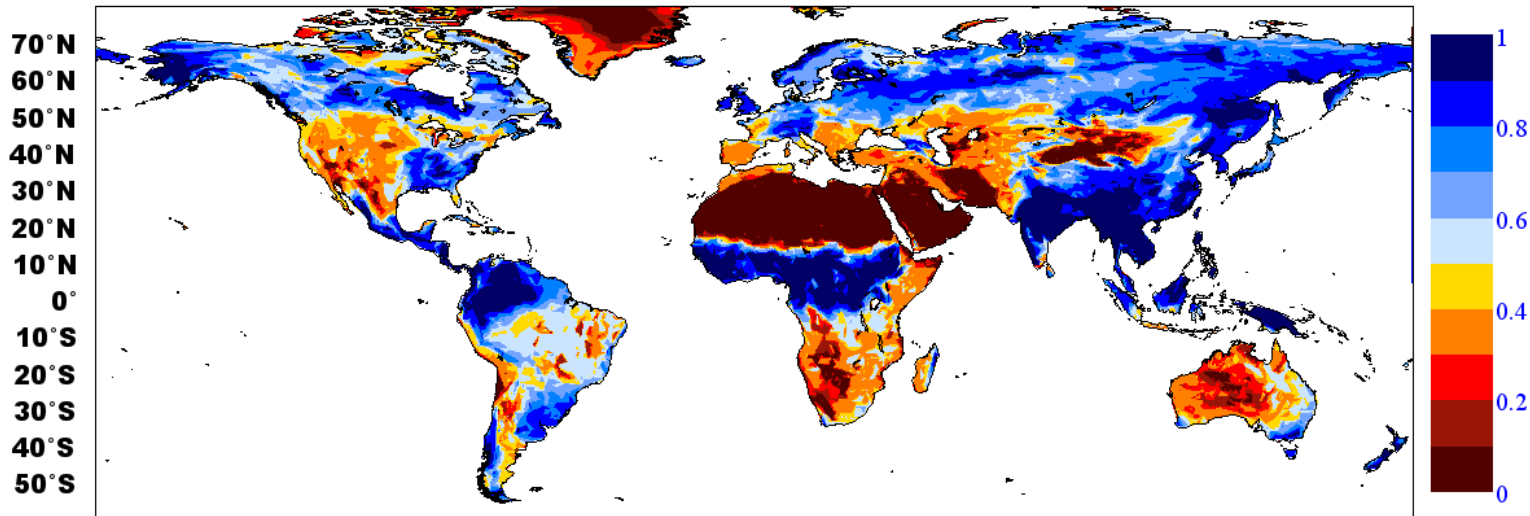

**H SAF**  
Support to Operational  
Hydrology and Water  
Management

# ASCAT soil moisture data assimilation

Available on 4 soil layers

ECMWF VT: Tuesday 4 September 2012 00UTC Surface:  
H14 H-SAF CDOP - Copyright © Eumetsat

Layer 3 (28-100 cm)

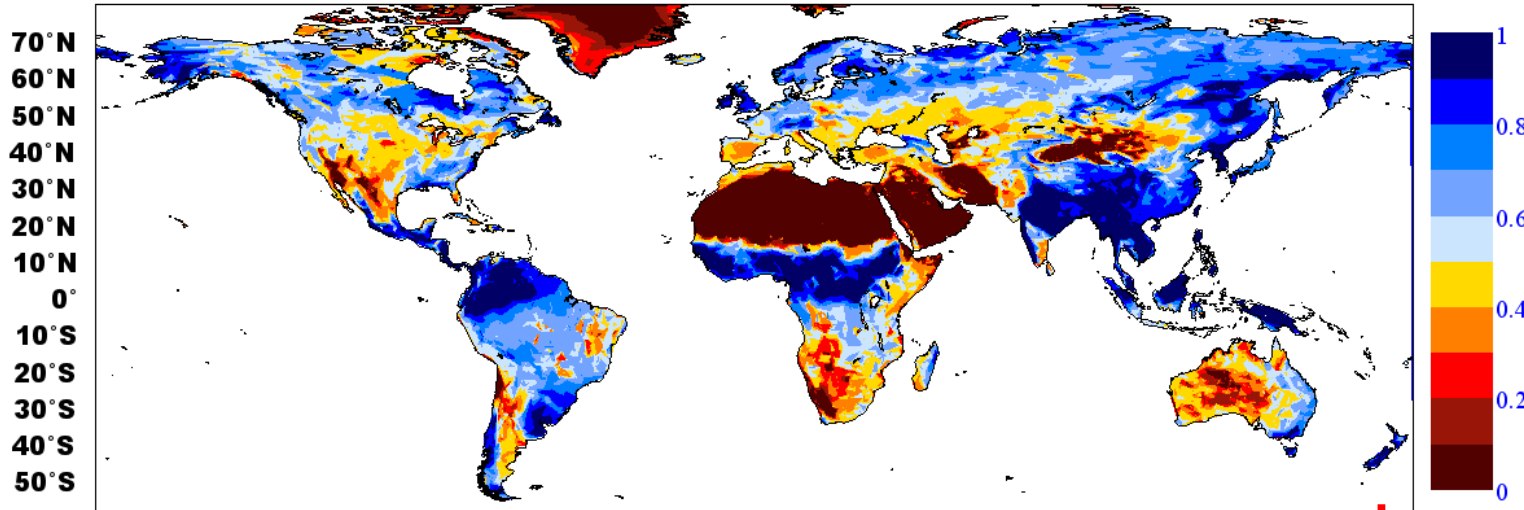

ECMWF VT: Tuesday 4 September 2012 00UTC Surface:  
H14 H-SAF CDOP - Copyright © Eumetsat

Layer 4 (1-3 m)

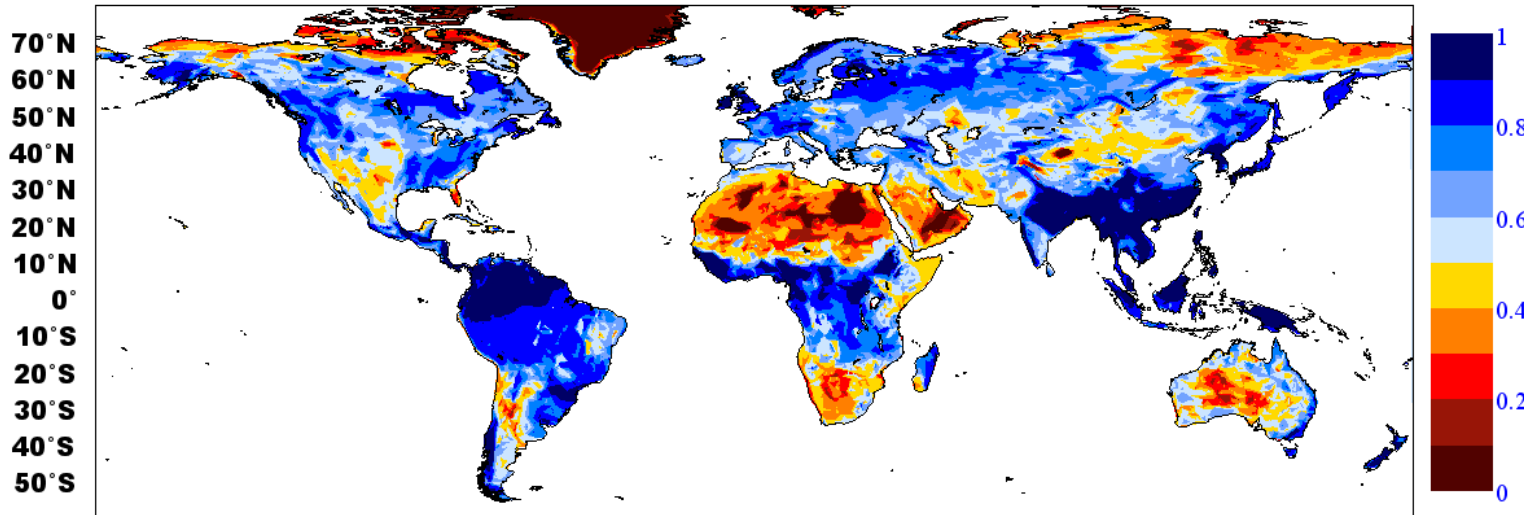

**H SAF**  
Support to Operational  
Hydrology and Water  
Management

# Satellite data for NWP soil moisture analysis

**Active microwave data:**  
**ASCAT:** Advanced Scatterometer  
 On MetOP-A (2006-), MetOP-B (2012-)  
 C-band (5.6GHz)  
**NRT Surface soil moisture**  
 Operational product  
 → ensured operational continuity

**Passive microwave data:**  
**SMOS:** Soil Moisture & Ocean Salinity  
 L-band (1.4 GHz), multi-angular  
**NRT Brightness Temperature**  
 Dedicated soil moisture mission  
 → Strongest sensitivity to soil moisture

STATISTICS FOR SOIL MOISTURE FROM METOP-B/ASCAT

STATISTICS FOR RADIANCES FROM FROM SMOS

Operational Monitoring of surface soil moisture related satellite data:  
 ASCAT soil moisture ( $m^3m^{-3}$ )                      SMOS Brightness temperature (K)

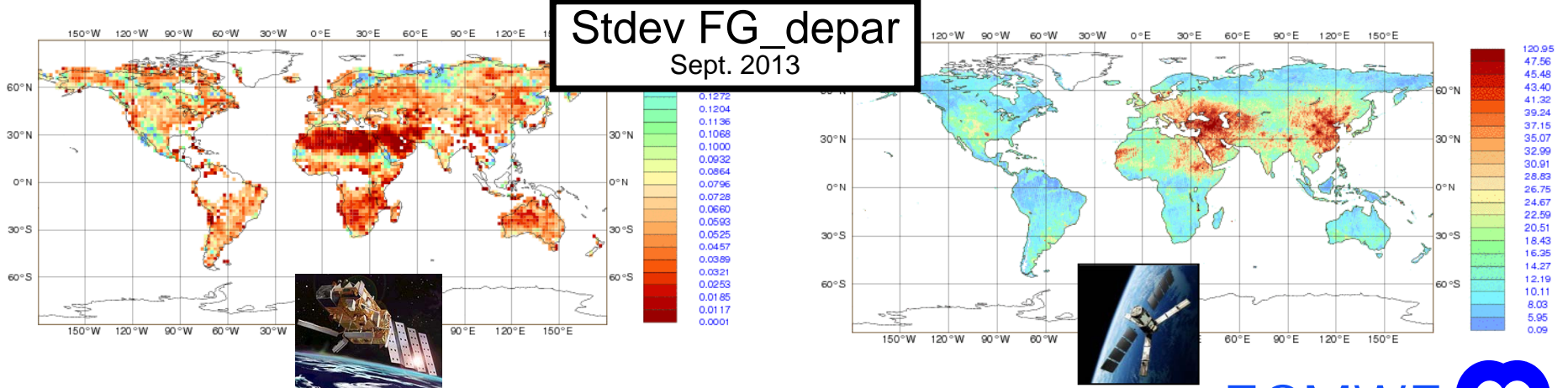

# SMOS Monitoring

Near real time (NRT) monitoring of SMOS TB at ECMWF  
(Muñoz Sabater et al. ECMWF Newsletter & IEEE TGRS 2011)

RFI (Radio Frequency Interference) sources impact on FG departures (Obs-model) : large standard deviation (StDev); Lots of RFI sources switched off in Europe, new sources identified in 2012, major issue in Asia.

STATISTICS FOR RADIANCES FROM FROM SMOS  
STDV OF FIRST GUESS DEPARTURE (ALL)  
DATA PERIOD = 2013-01-20 21 - 2013-02-22 21  
EXP = FGA5, CHANNEL = 1 (FOVS: 36-45)  
Min: 0.086 Max: 117.052 Mean: 15.794  
GRID: 0.25x 0.25

StDev first guess departure (Obs-Model)  
**Jan-Feb 2013**

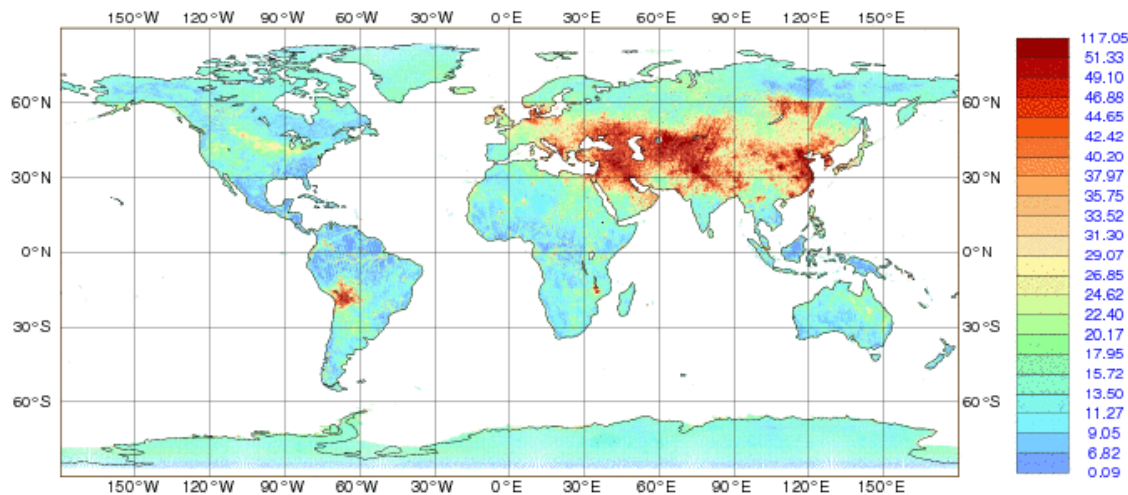

# Microwave emission modelling

- → **Forward operator: microwave emission model**
- **ECMWF Community Microwave Emission Modelling Platform (CMEM)**
- I/O interfaces for the Numerical Weather Prediction Community.

<https://software.ecmwf.int/wiki/display/LDAS/CMEM>

Also used at CMC, CSIRO, GSFC, and others centres

**Current version 4.1 (May 2012)**

## References:

Drusch et al. JHM, 2009  
de Rosnay et al. JGR, 2009  
de Rosnay, ESA Report, 2009

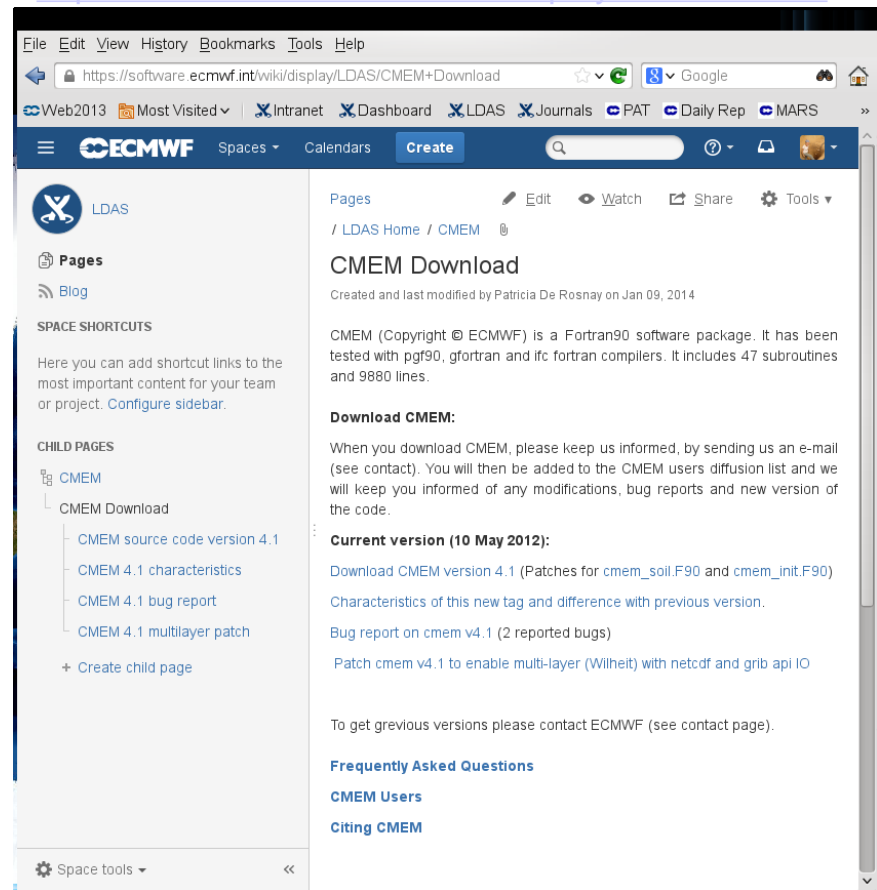

The screenshot shows a web browser displaying the ECMWF wiki page for CMEM Download. The page title is "CMEM Download" and it was created and last modified by Patricia De Rosnay on Jan 09, 2014. The main content describes CMEM as a Fortran90 software package with 47 subroutines and 9880 lines of code. It provides instructions on how to download CMEM and contact the developers. The page also includes a "Current version (10 May 2012)" section with links to download CMEM version 4.1, characteristics, bug reports, and patches. The left sidebar shows the page structure, including "CMEM Download" and "CMEM source code version 4.1".

# CMEM Simulations

ECMWF TB (K) ori WaWsWi\_TOA H 2010070106 at angle 30

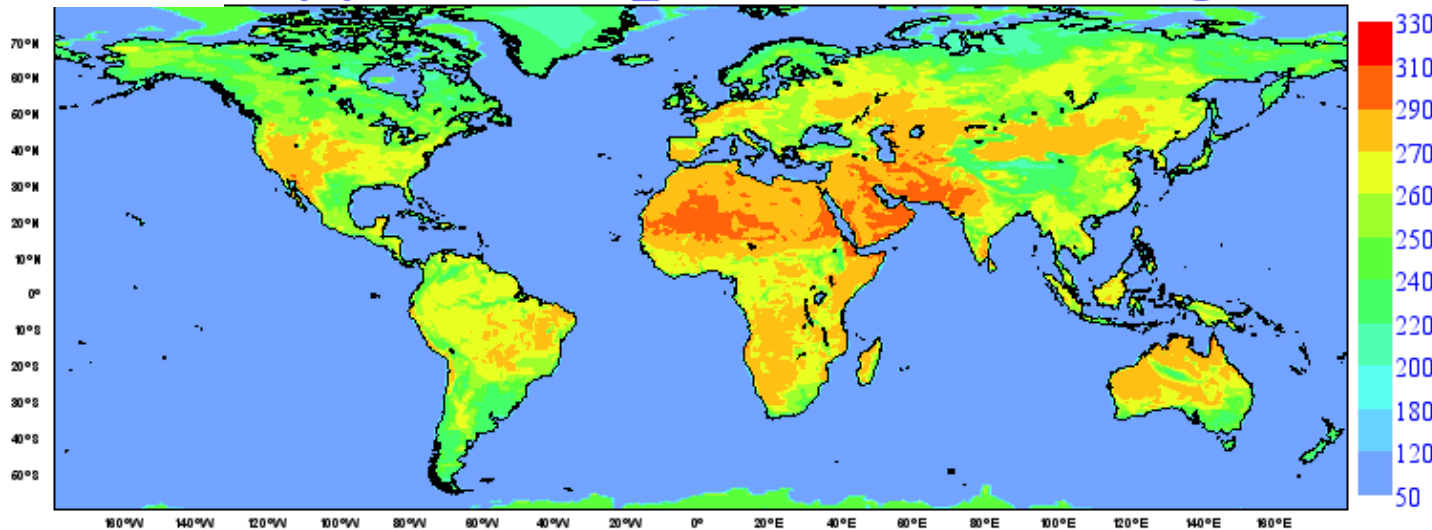

July  
2010  
TOA TBH

Before QC

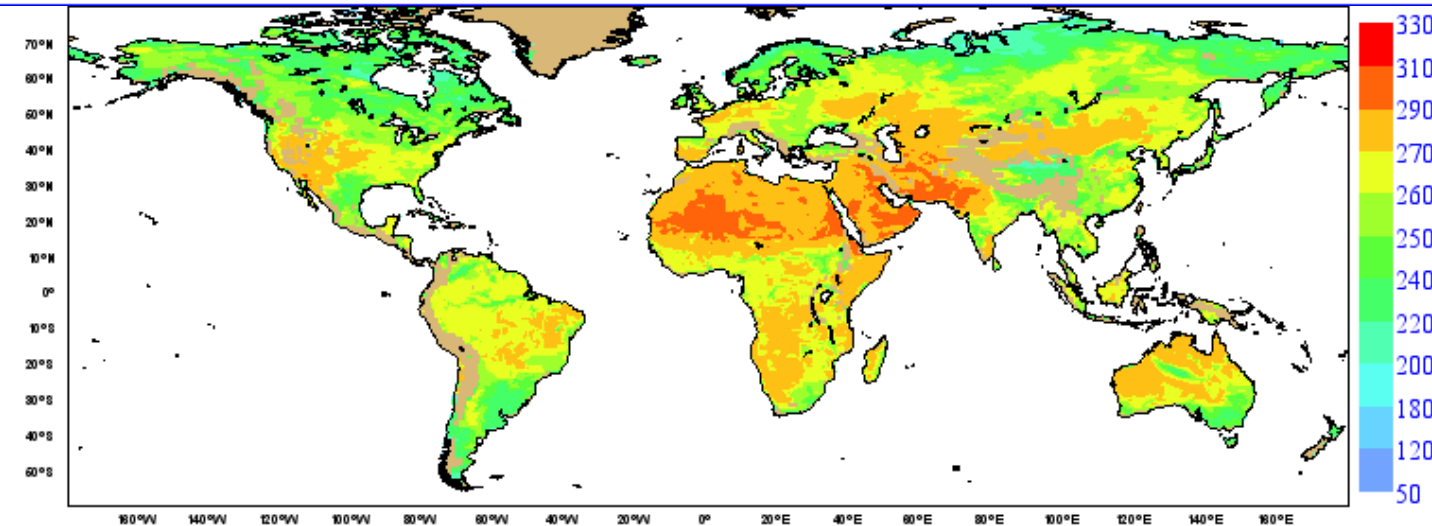

After QC  
(snow,  
Freeze,  
Orography)

# ECMWF SMOS forward operator and Bias correction

**SMOS forward operator:** Community Microwave Emission Modelling Platform (CMEM)  
CDF-matching matches mean and variance of two distributions

$$TB^*_{SMOS} = a + b TB_{SMOS}$$

with  $\overline{a} = \overline{TB_{CMEM}} - \overline{TB_{SMOS}} (\sigma_{CMEM} / \sigma_{SMOS})$   
 $b = \sigma_{CMEM} / \sigma_{SMOS}$   
→ Matches mean and variance

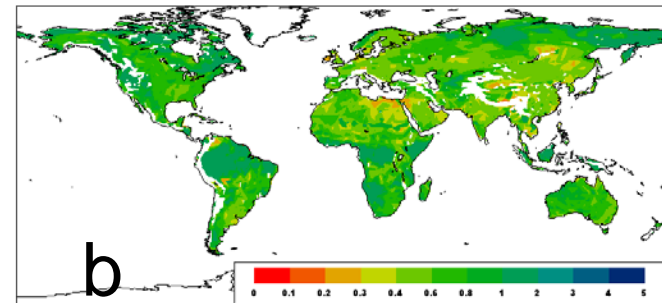
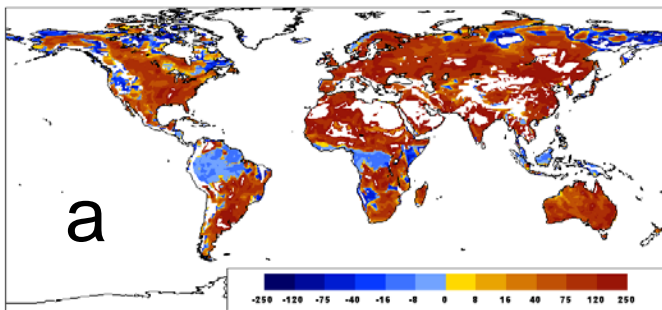

# ECMWF SMOS forward operator and Bias correction

**SMOS forward operator:** Community Microwave Emission Modelling Platform (CMEM)  
**CDF-matching** matches mean and variance of two distributions

$$TB^*_{SMOS} = a + b TB_{SMOS}$$

with  $a = \overline{TB}_{CMEM} - \overline{TB}_{SMOS} (\sigma_{CMEM} / \sigma_{SMOS})$   
 $b = \sigma_{CMEM} / \sigma_{SMOS}$   
 → Matches mean and variance

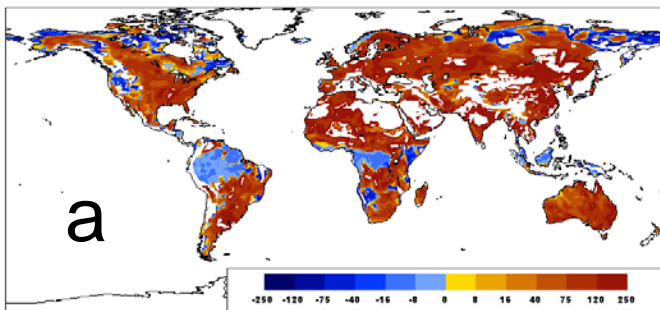
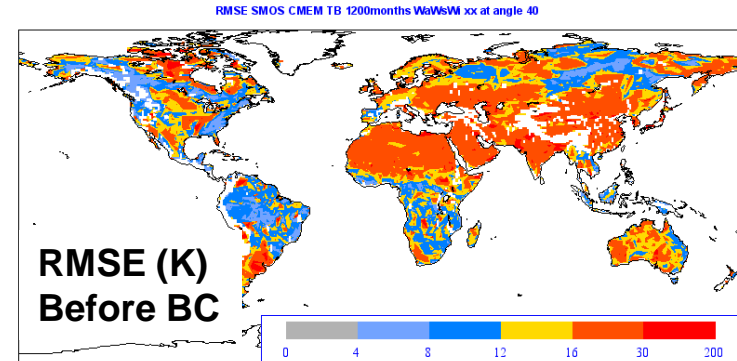

Evaluation for July 2012 →

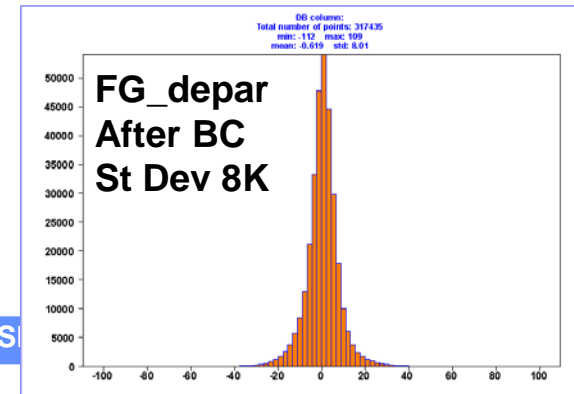
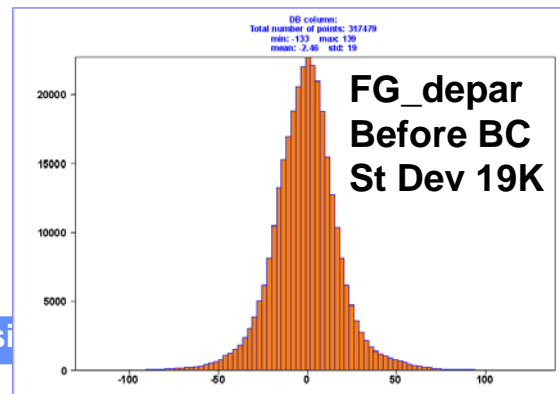
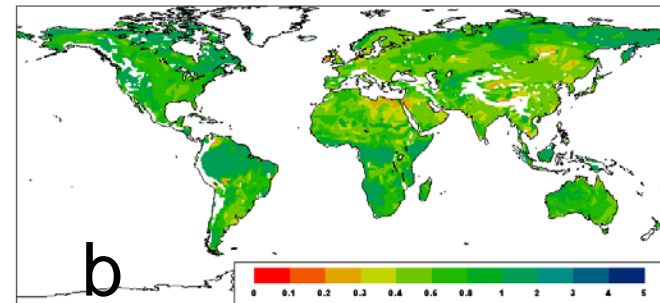
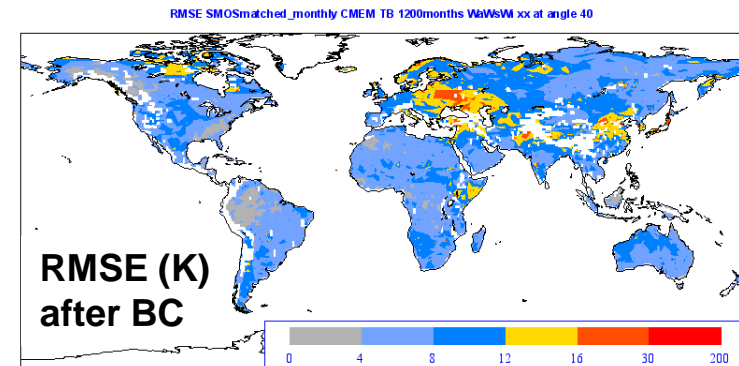



# Passive microwave remote sensing

Past current and future missions:

**Skylab**, NASA, L-band, 1973-1974 (but only 9 overpasses available)

**AMSR-E** 2002-2011 (Advanced Scanning Radiometer on Earth Observing System),  
NASA, C-band (6.9GHz)

**SMOS** (Soil Moisture and Ocean Salinity Mission): ESA Earth Explorer,  
L-band (1.4 GHz), launched November 2009

**First satellite specifically devoted to soil moisture remote sensing**

**AMSR-2** on GCOM-W1 (Global Change Observation Mission) launched in 2012

**SMAP** (Soil Moisture Active and Passive), NASA, L-band, to be launched in 2014  
**Also specifically designed for soil moisture → continuity of SMOS**

# Validation with in situ soil moisture data

Albergel et al.

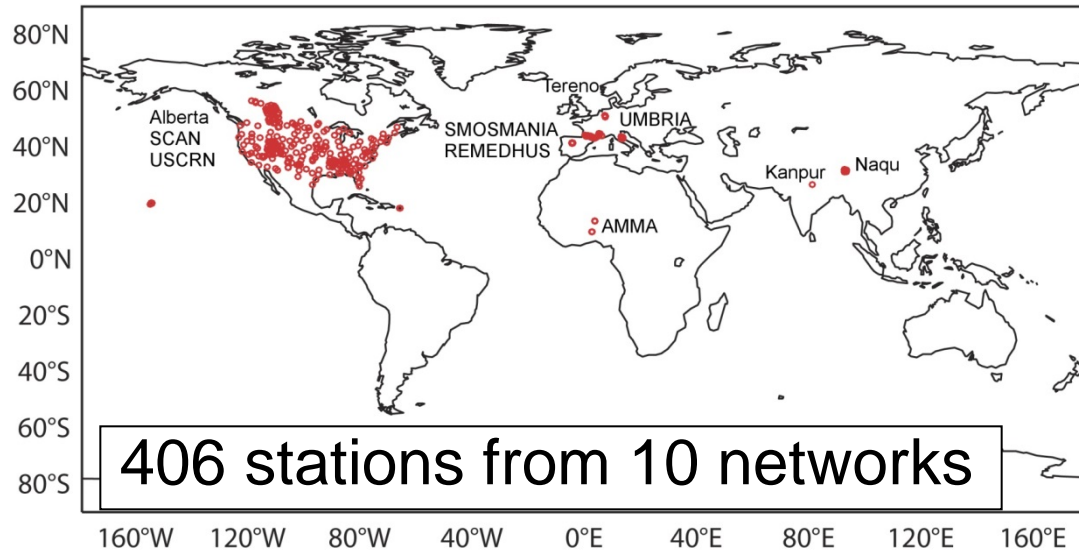

## International Soil Moisture Network

Validation for 2012 of ASCAT, SMOS and SM-DAS-2

For each station, time series are compared

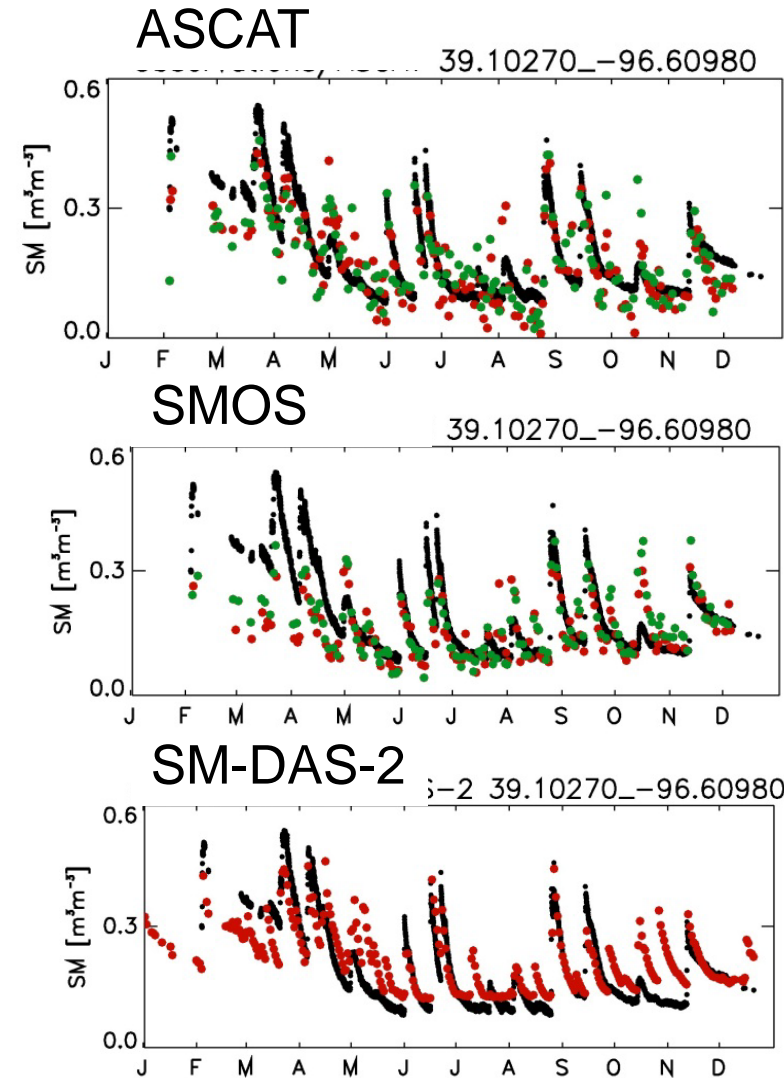

# Validation with in situ soil moisture data

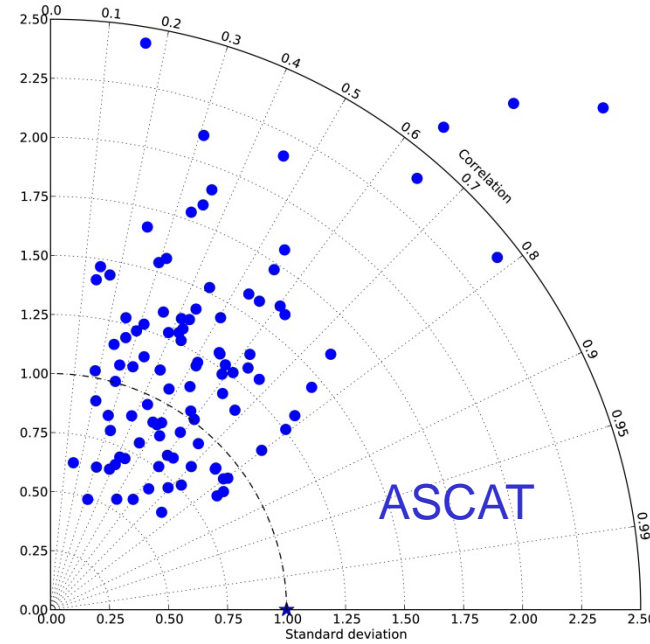
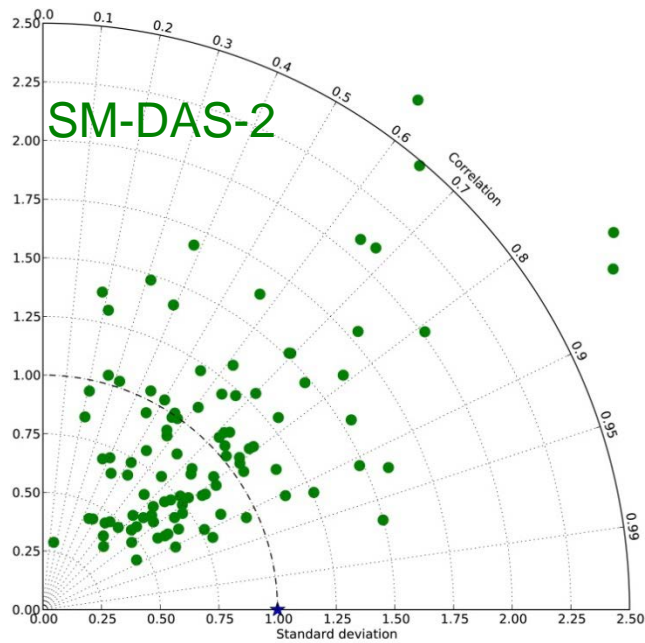

(USCRN)

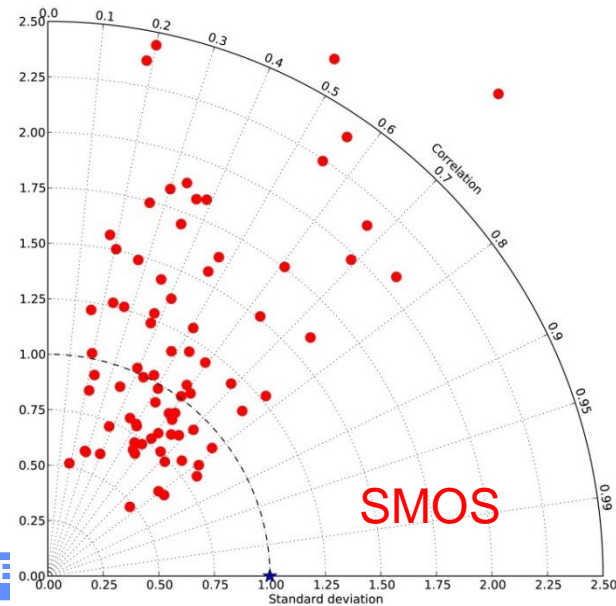

Correlation [-] (for stations with significant values)		
<i>SM-DAS-2</i>	<i>ASCAT</i>	<i>SMOS</i>
<b>0.67</b> (104 stations)	<b>0.50</b> (104 stations)	<b>0.50</b> (84 stations)

# Validation with in situ soil moisture data

Albergel et al. RSE, 2012

Normalized Product (nb stations with significant R)	SM-DAS-2 (333)	ASCAT (322)	SMOS (258)
Correlation	0.68	0.54	0.54
Bias (In Situ - Product)	-0.084	-0.005	0.027
RMSD	0.120	0.110	0.105

All products expressed  
as soil moisture index  
(no unit)

Normalized Product (nb stations with significant R)	SM-DAS-2 (310)	ASCAT (291)	SMOS (234)
Correlation on Anomaly	0.56	0.41	0.42

- SMOS and ASCAT surface soil moisture have similar quality
- Assimilated product (SM-DAS-2) has a larger bias, but in terms of dynamics it shows the best agreement with in situ soil moisture data

# Outline

## Part I

- Introduction
- Snow analysis
- Screen level parameters analysis

## Part II

- Soil moisture analysis
  - OI and EKF analyses
  - Use of Satellite data ASCAT and SMOS
- **Summary and future plans**

# Summary and future plans

- Most NWP centres analyse soil moisture and/or snow depth
- Land Data Assimilation Systems: run separately from the atmospheric 4D-Var
- Variety of approaches for snow and soil moisture
- **Operational snow analysis:**
  - Rely on simple analysis methods (Cressman, 2D-OI, or climatology)
  - Uses in situ snow depth data (SYNOP and national networks) and NOAA/NESDIS snow cover data
  - No Snow Water Equivalent products used for NWP (yet)

# Summary and future plans

## Operational Soil Moisture analysis systems for NWP:

- **Approaches:** **1D-OI** (Météo-France, CMC, ALADIN, HIRLAM, ECMWF ERA-I); **EKF** (DWD, ECMWF, UKMO); **Nudging** (BoM); **Offline LSM** using analysed atmospheric forcing (NCEP: GLDAS / NLDAS)
- **Data:** Most Centres rely on screen level data (**T2M and RH2m**) through a dedicated OI analysis, **ASCAT** (UKMO, ECMWF monitored & assimilated for EUMETSAT H-SAF)

Compared to the OI, the EKF analysis improves both Soil Moisture and T2m:

- Relevance of screen level parameters to analyse soil moisture
- Consistency in the LSM between soil moisture and screen level parameters

**Developments** of multi-variate approaches (ECMWF, CMC, Météo-France)

# Summary and Future plans

- Continuous developments to assimilate ASCAT soil moisture and SMOS brightness temperature in NWP systems
- Use of future satellites: NASA SMAP (launch November 2014)
- Assimilation of vegetation parameters (Leaf Area Index)
- Increase coupling between LDAS and 4D-Var
  
- Long term perspectives:
  - Importance of horizontal processes (river routing)
  - Assimilation of integrated hydrological variables such as river discharges: e.g. Surface Water Ocean Topography (SWOT 2019)



# Summary of ECMWF Land Surface Data Assimilation System

ECMWF  
January 2010



ASCAT

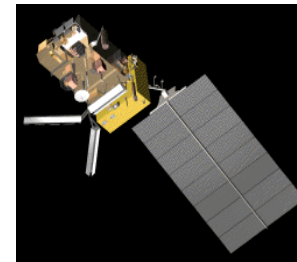

SMOS



## - Snow depth analysis

- 2D Optimal Interpolation (OI) (operational)
- Ground data (SYNOP and national networks data)
- High resolution NESDIS/IMS snow cover data

## -Screen level analysis

- 2D OI using SYNOP data

## -Snow and Soil Temperature

- 1D OI using T2m analysis increments as input

## - Soil Moisture analysis

- Simplified Extended Kalman Filter (EKF) (Operational)
- Uses screen level parameters analysis as input

## - Satellite data for Soil Moisture

METOP-ASCAT (H-SAF) and SMOS Monitoring

## Data assimilation

- for NWP
- for Root zone retrieval SM-DAS-2  
(operational for EUMETSAT H-SAF)

## - Validation activities

Rely on International Soil Moisture Network in situ soil moisture data base

## Further Reading:

**Integrated Forecasting System documentation (IFS cycle 40r1):**

<http://www.ecmwf.int/research/ifsdocs/CY40r1/>

**Land surface model, analysis and SMOS: ECMWF Newsletter 127, Spring 2011:**

<http://www.ecmwf.int/publications/newsletters/>

**ECMWF Surface analysis web pages:**

<https://software.ecmwf.int/wiki/display/LDAS/LDAS+Home>